

HARNESS DESIGNATION		
PIN 1	RED	SUPPLY (REGULATED 5V)
PIN 2	BLACK	SIGNAL
PIN 3	YELLOW	GnD
PIN 4	WHITE	Tx (FOR CONFIGURATION ONLY)
PIN 5	GREEN	Rx (FOR CONFIGURATION ONLY)

Configuration:	Arc
Calibrated sensing Range:	+/-95 degrees
Air Gap:	~3.5mm (see drawing)
Supply Voltage:	+5VDC +/-0.25V
Resolution:	12 bit
Update Rate:	5kHz
Output:	Analogue. Factory set to 0.25VDC @-5° – 4.75VDC @185°
Supply Current:	nom 45mA @ +5VDC
Reverse Polarity:	protected
Sensitivity:	Min. 23.6mV/degree
Termination:	JST PA, PAP-05V-S, 5 way
Wiring:	550mm, 5 core 26AWG sleeved in RW-200E
Sensor Dimensions:	Approx. 106mm x 80mm x 8mm (see drawing view)
Housing Material:	AL6082T6
Mounting:	2 x M4
Linearity:	+/- 0.4% full scale output
Operating Temperature:	-40 °C to 150 °C
Storage Temperature:	-20 °C to 85 °C
Vibration:	10G from 10Hz to 2,000Hz
Shock:	50 G half sine wave with 11 ms duration
Sealing:	IP67
Sensor Part Number:	LU-010-03
Target magnet assembly:	LU-014-01

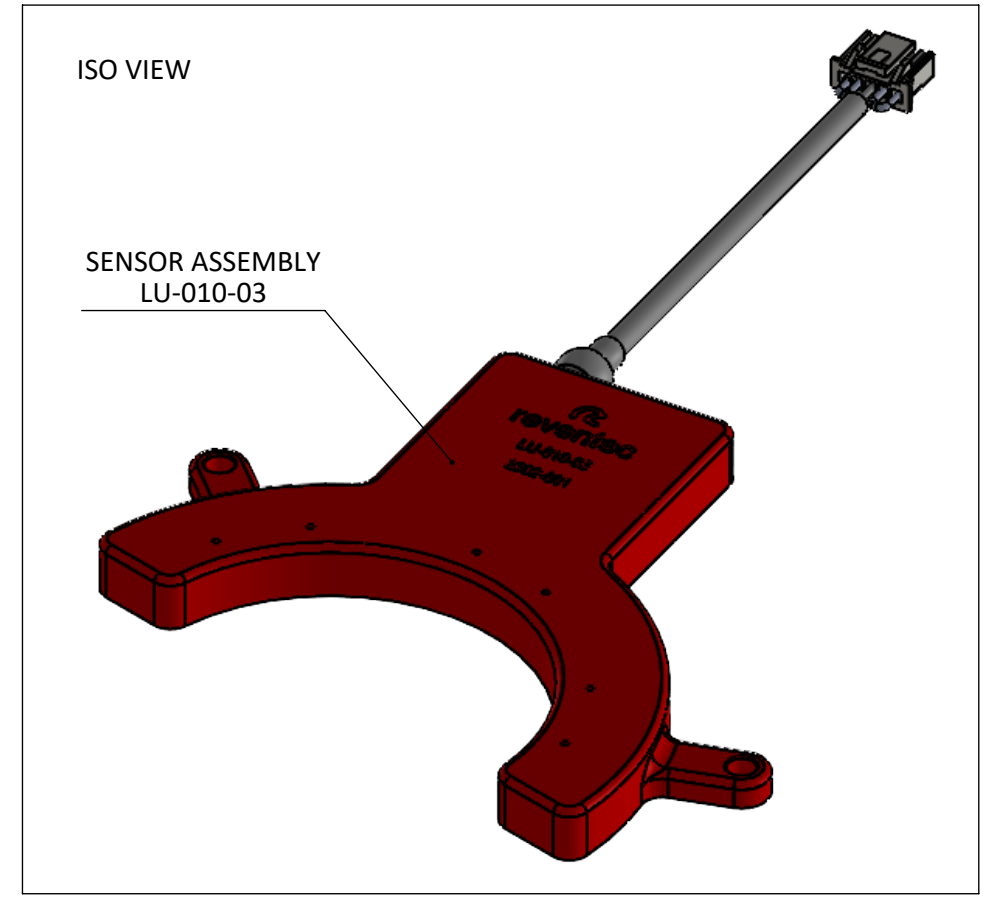

UNLESS OTHERWISE SPECIFIED: DIMENSIONS ARE IN MILLIMETERS SURFACE FINISH: TOLERANCES: LINEAR: ±0.05 ANGULAR: ±0.05		FINISH: ANODISED TO DEF STAN 03-25 COLOUR: RED	DEBUR AND BREAK SHARP EDGES	REVISION	ISSUE	DESCRIPTION	DATE	APPROVED
				01	FIRST RELEASE		17.12.22	NJM
				02	UPDATED TO 5V SUPPLY		23.03.23	NJM
				03	REVISED CABLE EXIT & MAGNET ASSEMBLY		28.08.23	NJM
DRAWN CHK'D APPV'D MFG Q.A		NAME SIGNATURE DATE	DATE 17.12.22	TITLE: 180° SENSOR ASSEMBLY				
MATERIAL: AL6082T6		THIRD ANGLE		DWG NO. LU-010-03		A3		
WEIGHT:				SCALE: 1:1		SHEET 1 OF 1		

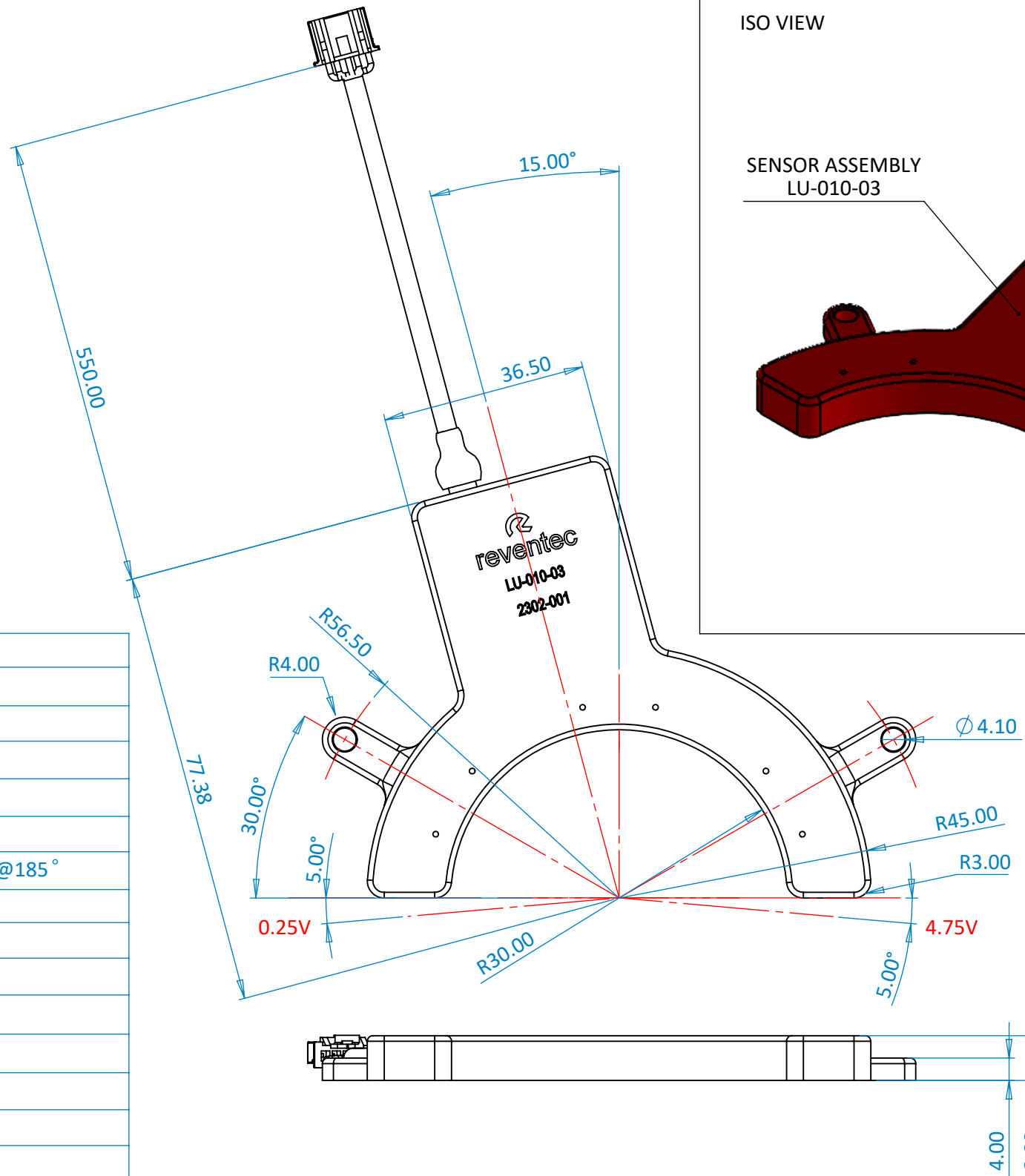